

Efficiency of Energy Conversion
SPN LESSON #24



TEACHER INFORMATION

LEARNING OUTCOME: After students become familiar with the first and second laws of thermodynamics and gain experience in reconverting electrical energy and determining efficiencies, they are able to describe conversion efficiencies and factors affecting those efficiencies and relate this to the school's PV system.

LESSON OVERVIEW: The purpose of this lesson is for students to experience the efficiency of energy conversion as a consequence of the laws of thermodynamics. They measure the power radiated by a light bulb. By comparing it with the electric power input to the light bulb, they calculate the efficiency with which the bulb converts electric energy into light. They then relate this to the efficiency with which the school's PV system converts light to electric energy. Data gathered in this lesson can be used in SPN lesson #25, *Dependence of Light Intensity on Distance* or vice versa. There are three alternatives offered within the student section of this lesson (the one you choose depends on the equipment present in your school):

- **Alternative 1:** a light bulb and a photovoltaic cell
- **Alternative 2:** a light bulb and a TI-83+/LabPro
- **Alternative 3:** a light bulb and a TI-83/CBL

GRADE-LEVEL APPROPRIATENESS: This Level III Physical Setting lesson is intended for use with students enrolled in a high school physics or physical science course.

MATERIALS:

Alternative 1: Student handout, meterstick, 100 W incandescent light bulb and fixture, ammeter (to read currents to the nearest hundredth of an ampere), voltmeter (to read voltages to the nearest millivolt), photovoltaic cell, connecting wires

Alternative 2: Student handout, meterstick, 40 W incandescent light bulb and fixture, TI-83+ graphing calculator, Vernier LabPro unit

Alternative 3: Student handout, meterstick, 40 W incandescent light bulb and fixture, TI-83 graphing calculator, TI CBL unit, TI light probe

SAFETY: Students need to take the usual precautions for handling electric appliances when setting up the bulb.

TEACHING THE LESSON: Have students recall the first and second laws of thermodynamics, and make sure they understand that while energy can be converted from one form to another

according to the first law, the influence of the second law makes it likely that the conversion to the desired “new” form will not proceed with 100% efficiency. Discuss the nature of the energy conversion to be investigated, using the content background information provided. Discuss also the operation of the equipment to be used to investigate the energy conversion, and have students collect and analyze data.

ACCEPTABLE RESPONSES FOR DEVELOP YOUR UNDERSTANDING SECTION:

Alternative 1: The following data and calculations were obtained on the 1-volt scale of a DC voltmeter and the 150 mA scale of a multimeter, with a 100 W incandescent bulb (with no ambient light) and a 5.5 cm x 3.8 cm photovoltaic cell:

Distance from center of bulb (m)	Voltage (V)	Current (A)	Power (W)	PV cell intensity (W/m ²)	Light bulb intensity (W/m ²)	Efficiency of conversion
0.1	1.40E-02	0.24	3.36E-03	1.61	796.	0.00202
0.2	8.00E-03	0.18	1.44E-03	0.689	199.	0.00346
0.3	6.00E-03	0.13	7.80E-04	0.373	88.5	0.00422
0.4	5.00E-03	0.1	5.00E-04	0.239	49.8	0.00481
0.5	4.00E-03	0.07	2.80E-04	0.134	31.8	0.00421

Note that the conversion efficiency for distances greater than .20 m is essentially independent of distance. It is expected that at closer distances the light bulb is so large relative to its distance to the photovoltaic cell that it cannot be truly considered a point source radiating equally through a sphere whose radius is the distance from the photovoltaic cell to the center of the bulb.

Alternative 2: The following data and calculations were obtained with a TI-83+/LabPro system:

Distance from center of bulb (m)	Received intensity (W/m ²)	Transmitted intensity (W/m ²)	Efficiency of conversion
0.4	4.53	19.9	0.227
0.5	4.44	12.7	0.348
0.6	2.77	8.85	0.313
0.7	2.26	6.50	0.348
0.8	1.73	4.98	0.348
0.9	1.33	3.93	0.338
1.0	1.06	3.18	0.331

Note that the conversion efficiency is essentially independent of distance. It is greater than the 5% efficiency of conversion from electric energy to visible light energy because the TI light probe is sensitive to frequencies ranging from 300 nm to 1100 nm. Only 400–700 nm represent visible light; the range of 700–1100 nm represents a considerable amount of infrared radiation, which is felt as heat.

Alternative 3: The following data and calculations were obtained with a TI-83/CBL system:

Distance from center of bulb (m)	Received intensity (W/m ²)	Transmitted intensity (W/m ²)	Efficiency of conversion
0.4	4.66	19.6	0.234
0.5	3.48	12.7	0.273
0.6	2.14	8.85	0.242
0.7	1.87	6.50	0.288
0.8	1.22	4.98	0.245
0.9	1.01	3.938	0.256
1.0	0.973	3.18	0.305

Note that the conversion efficiency is essentially independent of distance. It is greater than the 5% efficiency of conversion from electric energy to visible light energy because the TI light probe is sensitive to frequencies ranging from 300 nm to 1100 nm. Only 400–700 nm represent visible light; the range of 700–1100 nm represents a considerable amount of infrared radiation, which is felt as heat.

ADDITIONAL SUPPORT FOR TEACHERS

SOURCE FOR THIS ACTIVITY: This lesson is not adapted.

BACKGROUND INFORMATION: Two special features of the concept of energy are:

- 1) The amount of energy in a system is conserved unless work is done on the system or the system does work on something else.
- 2) Energy can be converted from one form to another.

These features of energy are quantitatively described by the first two laws of thermodynamics. The second law adds that in energy conversions the usefulness of the energy may decrease, although the total amount of energy remains the same. This lesson examines the conversion of electric energy to light in a light bulb, comparing the intensity of radiated energy (calculated on the basis of the rate at which the bulb uses electric energy) with the intensity of light energy actually received. The *efficiency* of a conversion from one form of energy to another is the ratio of the amount of energy converted to the “new” form to the amount of energy converted from the “old” form. This could also be expressed as a ratio of power (rate at which energy is converted to the “new” form divided by rate at which it is converted from the “old” form) or intensity (power divided by unit area). Power is expressed in watts, intensity in watts per square meter. In this lesson, electric energy is converted by a light bulb to light and by a photovoltaic cell back to electricity, and the intensities of both the original electric energy and the electric energy produced by the photovoltaic cell are determined. Most, if not all, of the electric energy not converted to the desired final form is given off as heat. Note: The data gathered in this lesson can also be used in the lesson on the inverse square law.

REFERENCES FOR BACKGROUND INFORMATION: none

LINKS TO MST LEARNING STANDARDS AND CORE CURRICULA: 1: M1.1, M2.1, S1.1, S3.1; 6: 2.2, 2.3; 4: 4.1a,b,e,f,g

Standard 1—Analysis, Inquiry, and Design: Students will use mathematical analysis, scientific inquiry, and engineering design, as appropriate, to pose questions, seek answers, and develop solutions.

Mathematics Key Idea 1: Abstraction and symbolic representation are used to communicate mathematically.

M1.1: Use algebraic and geometric representations to describe and compare data.

Mathematics Key Idea 2: Deductive and inductive reasoning are used to reach mathematical conclusions.

M2.1: Use deductive reasoning to construct and evaluate conjectures and arguments, recognizing that patterns and relationships in mathematics assist them in arriving at these conjectures and arguments.

Science Key Idea 1: The central purpose of scientific inquiry is to develop explanations of natural phenomena in a continuing, creative process.

S1.1: Develop extended visual models and mathematical formulations to represent an understanding of natural phenomena.

Science Key Idea 3: The observations made while testing proposed explanations, when analyzed using conventional and invented methods, provide new insights into phenomena.

S3.1: Use various means of representing and organizing observations (e.g., diagrams, tables, charts, graphs, and equations) and insightfully interpret the organized data.

Standard 6—Interconnectedness: Common Themes: Students will understand the relationships and common themes that connect mathematics, science, and technology and apply the themes to these and other areas of learning.

Interconnectedness Key Idea 2: Models are simplified representations of objects, structures, or systems used in analysis, explanation, interpretation, or design.

2.2: Collect information about the behavior of a system and use modeling tools to represent the operation of the system.

2.3: Find and use mathematical models that behave in the same manner as the processes under investigation.

Standard 4—The Physical Setting: Students will understand and apply scientific concepts, principles, and theories pertaining to the physical setting and living environment and recognize the historical development of ideas in science.

Key Idea 4: Energy exists in many forms, and when these forms change, energy is conserved.

4.1: Students can observe and describe transmission of various forms of energy.

4.1a: All energy transfers are governed by the law of conservation of energy.

4.1b: Energy may be converted among mechanical, electromagnetic, nuclear, and thermal forms.

4.1e: In an ideal mechanical system, the sum of the macroscopic kinetic and potential energies (mechanical energy) is constant.

4.1f: In a nonideal mechanical system, as mechanical energy decreases, there is a corresponding increase in other energies such as internal energy.

4.1g: When work is done on or by a system, there is a change in the total energy of the system.

Produced by the Research Foundation of the State University of New York with funding from the New York State Energy Research and Development Authority (NYSERDA)

www.nysesda.org

Should you have questions about this activity or suggestions for improvement, please contact Bill Peruzzi at billperuz@aol.com

(STUDENT HANDOUT SECTION FOLLOWS)

Alternative 1

Name _____

Date _____

Efficiency of Energy Conversion

The first law of thermodynamics tells us that energy can be converted from one form to another. The second law of thermodynamics tells us that the forms of energy after conversion may not be as useful as they were before the conversion took place. The incandescent light bulb is a good example of this: only about 5% of the energy it converts from electricity is actually converted to visible light.

DEVELOP YOUR UNDERSTANDING

The visible light from an incandescent light bulb can be converted back to electricity by means of a photovoltaic cell. To find the efficiency with which this can be done, connect a 10-ohm resistor and ammeter in series with the photovoltaic cell, to which you have also connected a voltmeter, as shown in the following diagram:

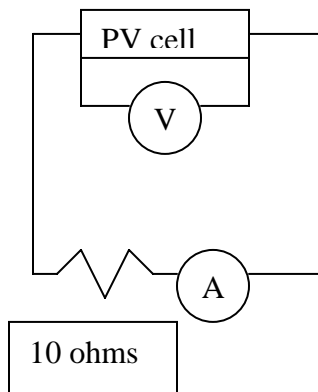

For best results, the ammeter and voltmeter should have scales that allow currents as small as a hundredth of an ampere and voltages as small as a thousandth of a volt to be read. Mount the photocell at various positions from a 100 W incandescent light bulb, from .10 to .50 meters from the center of the bulb, but make sure that a reliable voltmeter and ammeter reading can be obtained for each position. Then measure the voltage and current when the photovoltaic cell is at distances of 0.10 m, 0.20 m, 0.30 m, 0.40 m, and 0.50 m from the center of the light bulb, and record them in the following data table:

Distance from center of bulb (m)	Voltage (V)	Current (A)	Power (W)	PV cell intensity (W/m ²)	Light bulb intensity (W/m ²)	Efficiency of conversion
.10						
.20						
.30						
.40						
.50						

The power produced by the photovoltaic cell, in watts, is the product of the current and voltage. Calculate this value and insert the calculated values in the table above. This is the rate at which the photovoltaic cell produces electric energy. The intensity of this energy is found by dividing the power (in watts) by the area of the photovoltaic cell (in square meters); it is expressed in watts per square meter. To calculate the intensity of electric energy produced by the photovoltaic cell, calculate the area of the photovoltaic cell in square meters and divide it into the power produced by the photovoltaic cell in watts.

To find the efficiency with which the bulb and the photovoltaic cell convert electric energy back to electricity, we also need to know the intensity of energy emitted from the light bulb. To do this, realize that the light bulb radiates energy equally in all directions. This energy passes through a sphere around the bulb with a radius equal to the distance from the photovoltaic cell to the center of the bulb (this can be illustrated by a diagram). To find the intensity of the energy radiated from the bulb, divide the power of the bulb (rate at which it uses electric energy), in watts, by the area of this sphere (4 times pi times the square of the distance from the photovoltaic cell to the center of the bulb). Enter these calculated values into the table above.

Finally, to find the efficiency with which the bulb and photovoltaic cell convert the electric energy back to electricity, divide the intensity of electric energy produced by the photovoltaic cell by the intensity input to it from the light bulb, and enter these values into the table above. (Note: The calculations of intensity produced by the photovoltaic cell and intensity input from the bulb to the photovoltaic cell, and the calculation of efficiency of energy conversion, can be facilitated with a spreadsheet on a computer.)

1. How does the conversion efficiency depend on the distance from the light bulb to the photovoltaic cell?

Alternative 2

Name _____

Date _____

Efficiency of Energy Conversion (TI-83+/LabPro version)

The first law of thermodynamics tells us that energy can be converted from one form to another. The second law of thermodynamics tells us that the forms of energy after conversion may not be as useful as they were before the conversion took place. The incandescent light bulb is a good example of this: only about 5% of the energy it converts from electricity is actually converted to visible light.

DEVELOP YOUR UNDERSTANDING

The amount of energy converted from electricity to visible light by an incandescent light bulb can be measured with a light probe interfaced with a TI-83+/LabPro system, using the DataMate application, as follows:

1. Connect the light probe to CH 1 of the LabPro unit.
2. Make sure that the link cord is connected between the calculator and the LabPro unit (link ports are on the bottom of each unit).
3. Turn on the calculator and connect the AC adapter for the LabPro unit to a wall outlet.
4. Press the <APPS> key on the calculator.
5. Use the arrow keys on the calculator to highlight the application DataMate. Press <ENTER>. At this point the LabPro automatically checks for and identifies the probes connected to it. The calculator monitors and displays readings from the probes.
6. Press <1.Setup>.
7. Move the cursor to "Mode" and press <ENTER>.
8. Press <3.Events With Entry>.
9. Press <1.OK>.

10. Place a 40 W incandescent light bulb on a table and a meterstick with the “0” end at the center of the light bulb. Position the light probe so that it points directly to the light bulb and away from outside light, 40 cm from the center of the bulb. Eliminate all other ambient light in the laboratory.
11. Press <2.Start>. You will then be asked to press <ENTER> to collect data. Press <ENTER> when the reading on the calculator screen is stable, in order to register the intensity of the light at a distance of 40 cm from the bulb.
12. The calculator will now prompt you to input a value. Input 0.40 <ENTER> to indicate that this reading corresponds to a bulb-to-probe distance of 0.40 m.
13. Reposition the light probe so that it is 50 cm from the center of the bulb. Press <ENTER> when the reading is stable, in order to register the intensity of the light at a distance of 50 cm from the bulb. When prompted to input a value, input 0.50 <ENTER> to indicate that this reading corresponds to a bulb-to-probe distance of 0.50 m.
14. Repeat step 13 for distances of 60 cm, 70 cm, 80 cm, 90 cm, and 100 cm, entering, respectively, values of 0.60, 0.70, 0.80, 0.90, and 1.00.
15. After your last measurement, press <STO-> to see a graph of the light intensities versus distance from bulb to probe (the window for the x -axis will match the range of distance values you have input).
16. Press <6.Quit>. You will be told that the distances will be displayed in L_1 and the light intensities in L_2 . This can be verified by pressing <ENTER> (to exit the DataMate application), then pressing <STAT> and selecting EDIT. The intensities are measured in units of milliwatts per square centimeter. To convert them to watts per square meter, multiply the values in L_2 by 10.
17. Enter the light intensities (in watts per square meter) in the column headed “received intensity” and the distances from the light probe to the center of the light bulb (in meters) into the following data table:

Distance from center of bulb (m)	Received intensity (W/m^2)	Transmitted intensity (W/m^2)	Efficiency of conversion
0.40			
0.50			
0.60			
0.70			
0.80			
0.90			
1.00			

18. To find the efficiency with which the light bulb converts electric energy into visible light, we need to know the intensity of energy transmitted from the light bulb. To do this, realize that the light bulb radiates energy equally in all directions. This energy passes through a sphere around the bulb with a radius equal to the distance from the light probe to the center of the bulb (this can be illustrated by a diagram). To find the intensity of the energy radiated from the bulb, divide the power of the bulb (rate at which it uses electric energy), in watts, by the area of this sphere (4π times the square of the distance from the photovoltaic cell to the center of the bulb). Enter these calculated values into the column headed “transmitted intensity” in the table above.

Finally, to find the efficiency with which the light bulb converts electric energy into visible light, divide the received intensity (as measured by the light probe) by the transmitted intensity (from the light bulb), and enter these values into the table above. (Note: The calculations of intensity input from the bulb and efficiency of energy conversion can be facilitated with a spreadsheet on a computer.)

Question: How does the conversion efficiency depend on the distance from the light bulb to the photovoltaic cell?

Suggestion for further experimentation: Repeat the above procedure with an incandescent bulb of a different power rating or with a compact fluorescent bulb. What differences do you observe? (Note: A 100 W incandescent bulb is found to “overload” a TI light probe at distances closer than 0.50 m.)

Alternative 3

Name _____

Date _____

Efficiency of Energy Conversion (TI-83/CBL version)

The first law of thermodynamics tells us that energy can be converted from one form to another. The second law of thermodynamics tells us that the forms of energy after conversion may not be as useful as they were before the conversion took place. The incandescent light bulb is a good example of this: only about 5% of the energy it converts from electricity is actually converted to visible light.

DEVELOP YOUR UNDERSTANDING

The amount of energy converted from electricity to visible light by an incandescent light bulb can be measured with a light probe interfaced with a TI-83/CBL system, using the PHYSICS program, as follows:

1. Connect the light probe to CH 1 of the CBL unit.
2. Connect the link cord between the calculator and the CBL unit (link ports are on the bottom of each unit). Make sure that the link cord is firmly inserted into each unit (a twisting motion helps to ensure this).
3. Turn on the CBL unit and calculator.
4. Press the <PRGM> key on the calculator.
5. Use the arrow keys on the calculator to highlight the program PHYSICS. Press <ENTER>. At this point the calculator screen should have “prgmPHYSICS” showing; press <ENTER> again.
6. When the program title screen appears, press <ENTER>, as prompted on the screen.
7. If it is not already highlighted, highlight 1:SET UP PROBES and press <ENTER>.
8. At the prompt “ENTER NUMBER OF PROBES,” press <1> and <ENTER>.
9. Select <7.MORE PROBES>. (This can be done by pressing <7> or using the arrow keys to select <7.MORE PROBES> and pressing <ENTER>.) Then select <1.LIGHT>.
10. When prompted to select a channel, press <1> and <ENTER>.

11. You should now be back at the main menu screen. Select <2.COLLECT DATA>.
12. From the data collection menu choose <3.TRIGGER PROMPT>. The CBL/Calculator pair is now prepared to gather data.
13. Place a 40 W light bulb on a table and a meterstick with the “0” end at the center of the light bulb. Position the light probe so that it points directly to the light bulb and away from outside light, 40 cm from the center of the bulb. Eliminate all other ambient light in the laboratory.
14. Monitor the CBL and press <TRIGGER> on the CBL unit when the reading is stable. The calculator will now prompt you to input a value. Input 0.40 <ENTER> to indicate that this reading corresponds to a bulb-to-probe distance of 0.40 m.
15. Reposition the light probe so that it is 50 cm from the center of the bulb. From the data collection menu choose <1.MORE DATA>. Monitor the CBL and press <TRIGGER> on the CBL unit when the reading is stable. The calculator will now prompt you to input a value. Input 0.50 <ENTER> to indicate that this reading corresponds to a bulb-to-probe distance of 0.50 m.
16. Repeat step 15 for distances of 60 cm, 70 cm, 80 cm, 90 cm, and 100 cm, entering, respectively, values of 0.60, 0.70, 0.80, 0.90, and 1.00.
17. After your last measurement choose <2.STOP AND GRAPH> from the data collection menu. The calculator will display a graph of light intensity (in L_2) versus distance (in L_1).
18. After you have finished viewing your graph, press <ENTER> and respond to the prompt “REPEAT?” If you wish to collect more data, input <2.YES>; otherwise, input <NO>, and select <7.QUIT> from the main menu.
19. The intensities in L_2 are measured in units of milliwatts per square centimeter. To convert them to watts per square meter, multiply these values by 10.
20. Enter the light intensities (in watts per square meter) in the column headed “received intensity” and the distances from the light probe to the center of the light bulb (in meters) in the following data table:

Distance from center of bulb (m)	Received intensity (W/m ²)	Transmitted intensity (W/m ²)	Efficiency of conversion
0.40			
0.50			
0.60			
0.70			
0.80			
0.90			
1.00			

21. To find the efficiency with which the light bulb converts electric energy into visible light, we need to know the intensity of energy transmitted from the light bulb. To do this, realize that the light bulb radiates energy equally in all directions. This energy passes through a sphere around the bulb with a radius equal to the distance from the light probe to the center of the bulb (this can be illustrated by a diagram). To find the intensity of the energy radiated from the bulb, divide the power of the bulb (rate at which it uses electric energy), in watts, by the area of this sphere (4 times pi times the square of the distance from the photovoltaic cell to the center of the bulb). Enter these calculated values into the column headed “transmitted intensity” in the table above.

Finally, to find the efficiency with which the light bulb converts electric energy into visible light, divide the received intensity (as measured by the light probe) by the transmitted intensity (from the light bulb), and enter these values into the table above. (Note: The calculations of intensity input from the bulb and the efficiency of energy conversion can be facilitated with a spreadsheet on a computer.)

Question: 1. How does the conversion efficiency depend on the distance from the light bulb to the photovoltaic cell?

2. Record the solar input to and the DC and AC output from your school’s photovoltaic system. Record the array efficiency (for conversion from solar input to DC output), the inverter efficiency (for conversion from DC output to AC output), and the system efficiency (from solar input to AC output). How would you expect the system efficiency to be related to the array and inverter efficiencies? Is your expectation borne out by the numerical values you have recorded for these efficiencies?

Suggestion for further experimentation: Repeat the above procedure with an incandescent bulb of a different power rating or with a compact fluorescent bulb. What differences do you observe? (Note: A 100 W incandescent bulb is found to “overload” a TI light probe at distances closer than 0.50 m.)